

Radiation Management for Interventional Fluoroscopy

Patient Radiation Management



Stephen Balter, Ph.D.
Clinical Associate Professor
Columbia University Medical Center

Intro

The statements and opinions in this document are those of the author and may not reflect those of any other individual or organization.

Thanks and acknowledgments are extended to the following individuals for their help in reviewing and editing this document: M. Egan, RN; A. Gupta, MD; J. Kamen, PhD; S. Loksen, MS; D. L. Miller, MD; J. W. Moses, MD; E. J. Nickoloff, DSc; T.B. Shope Jr., PhD; L.K. Wagner, PhD.

Caution: Institutional policies and procedures, professional society guidelines, and applicable governmental regulations take precedence over the general educational materials provided in this work.

This document was made possible by an unrestricted educational grant supplied by Siemens Medical Solutions, Forchheim, Germany.

© 2006 by Stephen Balter, Ph.D., NY, NY
No part of this document may be reproduced
without permission of the author.
Contact: e-mail: sb2455@columbia.edu

Exposing Patients to X-rays

The medical use of radiation is unique. Procedural benefits go to the patient; the risks are born by both patient and staff. Fluoroscopically guided invasive procedures can be highly effective and beneficial to patients. Exposing patients to ionizing radiation exposes them to the stochastic risks of radiation and may also induce deterministic injuries.

The decision to perform (or continue) a procedure should be made after considering the expected benefits of the procedure, all of the risks of the procedure (not just radiation), the risks of alternative procedures, and the risks of doing nothing.

Some aspects of image quality increase as the amount of patient irradiation increases. An operator needs sufficient image quality to optimally perform the procedure. Too low an exposure rate can produce images of such poor quality that the operator is impeded by poor visibility. This can slow the procedure and may actually increase the total dose. Too high an exposure rate can produce very high quality images. Increasing radiation produced image quality beyond the level needed to confidently perform the procedure wastes radiation.

The need to appropriately use radiation has been known for a century. By substituting the word 'intervention' for the word 'therapeutic', the following advice is strikingly modern: "We may safely expect that (...) Roentgen burns caused during diagnostic exposures will become more and more infrequent. But with the employment of the rays for therapeutic purposes burns have now become a rather common accident. Where cosmetic considerations alone are concerned, such heroic therapy is injudicious". Kassabian 1907 (died of radiation induced malignancy)

Exposing the patient usually also exposes both operators and staff. In general, increased patient exposure results in increased staff exposure.

Deterministic Injuries



two months

six months

two years (before grafting)

Time Course of a major radiation injury

Source USFDA - CDRH

Radiation injuries are not thermal burns. The X-rays that caused the injury shown in the figure contained the energy equivalent of less than a teacup of warm water. Radiation injuries are caused by molecular interactions with DNA and other cellular components.

Deterministic radiation injuries will always occur if the dose delivered to a volume of tissue is high enough. There is a relatively small range of threshold doses attributed to biological variability and health status (lower threshold in diabetics). The root causes of deterministic injuries are usually related to the operator's choices of technical and procedural factors.

**Radiation injuries are not thermal burns.
Injuries always occur at sufficiently high dose.
The operator is the cause of high dose.**

Severity of Injury

Grade	PSD Gy	Prodromal Stage	Latent Stage	Manifest Illness Stage	Recovery	Late Effects
I (a)	>2	Not Seen --	No Injury Evident	redness, slight edema, pigmentation; 6 weeks dry desquamation (20-30 days)	Complete in 1 - 6 months	Possible Slight Atrophy Late Skin Ca
I (b)	2 - 5	1 - 2 days redness	---			
I (c)	5 - 15		5 - 2 weeks			
II	15 - 40	redness (h), immediate sensation of heat (1 - 2 days)	No Injury Evident --- 3 - 1 weeks	redness, edema, epilation, pain, blood vessel injuries	Depends on size of injury, number of erythema cycles	Possible Atrophy or Ulcer; Late (10y) Telangiectasia
III	40 - 550	immediate pain (1-2 d) redness in 4 - 24 hours	2 weeks to none	Redness, pain, blisters, ulcers, possible necrosis	Can involve ulcer that are extremely difficult to treat (months to years)	Possible Atrophy, Ulcer, Sequella of small vessel distraction; Late Skin Ca

Adapted from CDC 2005 by SB 2006

Deterministic radiation injuries occur when large numbers of cells are killed. Cells may die immediately after irradiation or later during attempted cell division. Thus, the full severity of a radiation injury can take weeks to months to appear. This table was prepared by the United States Center for Disease Control.

Higher Peak Skin Doses (PSD) result in more total and immediate cell deaths. Thus high PSD produces injuries that are both more severe and express themselves more rapidly. Interventional PSDs in above 15 Gy result in major injuries.

Radiation injuries heal if surviving cells produce enough viable offspring to repopulate the affected tissue. Some tissues, such as small vessels, heal poorly; this results in residual injury.

Deterministic injuries are not seen at low PSD.
Higher PSDs result in more severe injuries.
Prompt pain is a symptom of a major injury.

Stochastic Risk

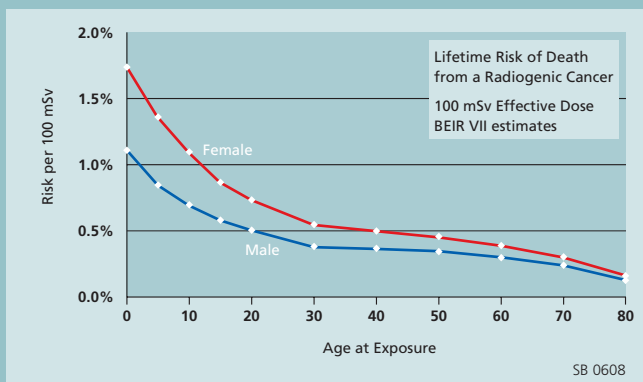

Lifetime Cancer Mortality Attributable to a Major Intervention

The lifetime risk of death from a radiation induced cancer is proportional to the effective dose (E) received by the patient. Risks are affected by the patient's sex and age at the time of the procedure. Disease is expressed years to decades later.

The natural lifetime risk of a cancer death is 24% for a male and 20% for a female.

E is proportional to the KAP used during a procedure and the irradiated body parts. Factors are available in the literature.

The figure shows the risk associated with an effective dose of 100 mSv. Most invasive diagnostic procedures are approximately 10 mSv. Major interventions can exceed 100 mSv.

Stochastic risk is proportional to KAP.
Other factors include procedure type and patient age.
In most adult procedures, the stochastic risk is small compared to other risks of the procedure.

Fetal Risks from Irradiation

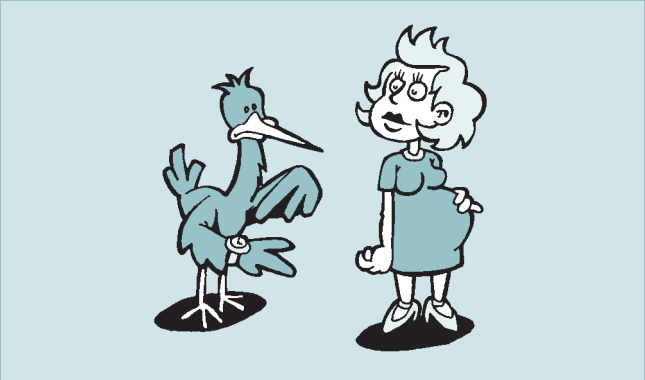

Irradiation of a fetus subjects it to the risk of stochastic injury, and at high (fetal) dose the induction of a deterministic effect.

A safe policy is to avoid elective procedures during pregnancy. However, in emergent or urgent cases, most interventional procedures performed above the mother's diaphragm can be modified to yield minimal fetal doses. (Typically less than 1 mSv.)

Gestation has other risks. Noticeable malformations occur in 5% of live births in the absence of known risk factors.

The benefits and risks to both mother and fetus of performing or not performing a planned procedure needs careful consideration. Informed patient consent is vital.

A safe policy is to avoid performing elective procedures during pregnancy.

Many emergent or urgent procedures can usually be performed with minimal fetal risk.

Patient Dose Factors

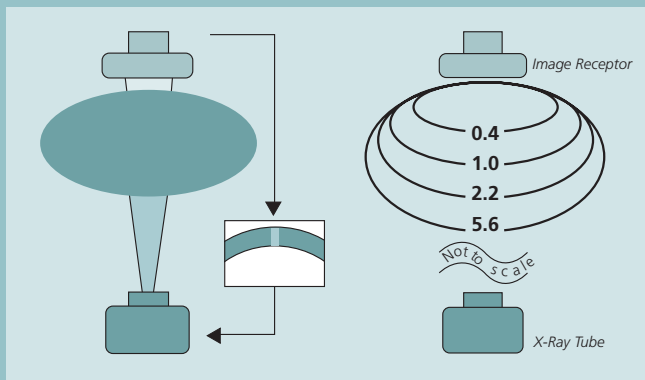

Automatic dose rate controls adjust X-ray output to obtain constant image receptor dose and therefore acceptable image quality for different patients and views. In most cases, longer tissue paths for the X-ray beam result in both higher skin and effective doses. Skin dose rate also increases rapidly as the entrance port is moved closer to the X-ray tube.

Skin injuries and hair loss occur when the local dose delivered to a portion of the patient's skin exceeds the biological threshold. If there are sufficient changes in beam angulation, different portions of skin are irradiated at different times. Thus changing views during the procedure reduces the probability of exceeding dose thresholds for any specific skin region.

Longer tissue paths for the X-ray beam result in higher skin and effective doses.

Changing angles reduces peak skin dose.

Time

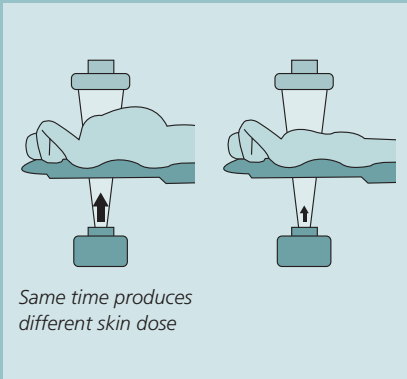

Fluoroscopic time has been used for generations as an indicator of radiation risk. The five-minute buzzer is there to remind the operator of the passage of time. However, fluoro time is only one of many factors that contribute to patient dose.

Interventional procedures involve both fluoroscopy and acquisition (DSA or cine). The fluoroscopic contribution varies widely between procedure types and even within a type.

With a fixed beam, the patient's skin dose is the product of dose rate and fluoroscopic time. Dose rates vary widely in response to the operator's settings and the patient's size.

Fluoro time can not account for beam motion during the case.

Fluoroscopic time can not be used to accurately estimate peak skin dose because it does not account for fluoroscopic dose rate, cine or DSA images, patient size, or beam motion.

Kerma Area Product (KAP)

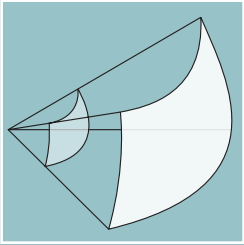

KAP Chamber (highlighted) intercepts the entire X-ray beam

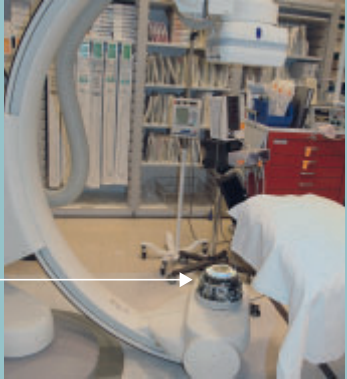

Kerma Area Product (KAP) is the product of the air kerma rate at a specified distance from the X-ray source and the cross section area of the X-ray beam at the same distance. Air kerma rate decreases as the square of distance; field size increases with the square of distance. Therefore KAP is independent of distance. (Sometimes labeled as Dose Area Product (DAP)).

KAP is the total amount of X-rays leaving the tube. It is a good metric for assessing stochastic risk to both patients and staff.

KAP can be used to estimate skin dose knowing the field size (FS) at the patient's skin. $KAP/FS = \text{"Skin Dose"}$. This equation overestimates PSD if there is substantial beam motion during the procedure. Adding physics details improves the estimate.

- Kerma Area Product (KAP) is a measure of the total amount of radiation leaving the X-ray tube.
- KAP is a good indicator of stochastic risk.
- KAP + geometry can be used to estimate skin dose.

Dose at Reference Point

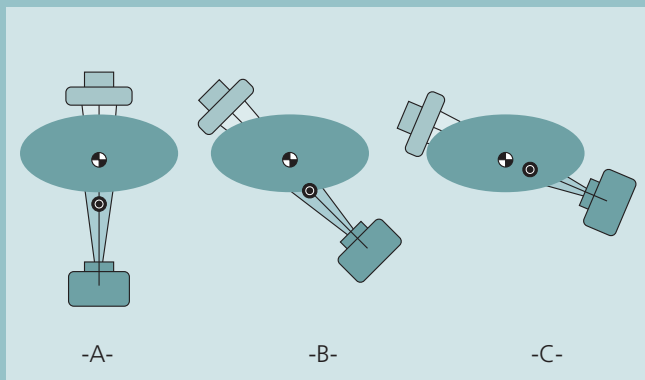

The Dose Reference Point is fixed to the system gantry. It is typically 15 cm on the X-ray tube side of isocenter. This is an approximation of the patient's skin position (B). In (A), the skin is further away than the reference point. In (C) it is closer.

The system totals the air kerma from fluoroscopy and acquisitions at the reference point as a procedure progresses. In the absence of beam motion (A) will overread, (B) will be correct, and (C) will underread the air kerma at the patient's skin.

Because the reference point moves with the gantry, beam motion will spread the dose over different patches of skin. Thus, with typical beam motion during a procedure, reference point dose usually exceeds Peak Skin Dose.

The Dose Reference Point is the total air kerma produced during an entire procedure.

The Reference Point moves with the gantry. It can overestimate PSD with sufficient gantry motion.

Mode Selection

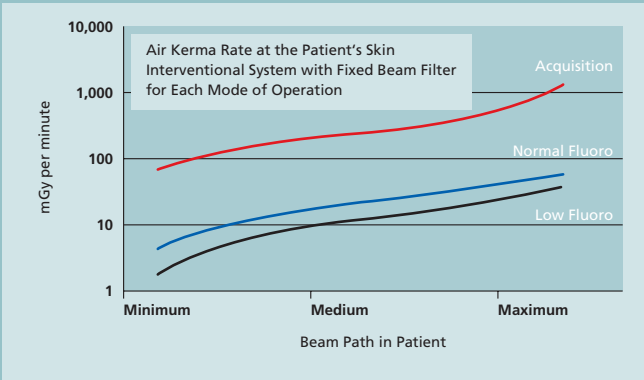

Interventional fluoroscopes have many operator selectable modes of operation. Each is intended to provide an optimized balance between dose and image quality for a specific purpose.

The figure illustrates skin dose rates for two fluoro and one acquisition mode (cine in this example) of a typical system. Here, the two fluoro modes differ by a factor of two over the entire range of patient thickness. Acquisition also tracks with patient thickness but at a much higher dose rate. Inappropriate use of acquisition will greatly increase patient dose.

Newer systems can retrospectively store fluoroscopy. This will result in considerable patient dose saving when used for documentation in place of subsequent acquisition runs.

Fluoro systems have many modes and sub-modes.

Dose rates can change by a factor of more than 10 by changing the major mode. Changing sub-mode can change rate by a factor of 2.

Geometry

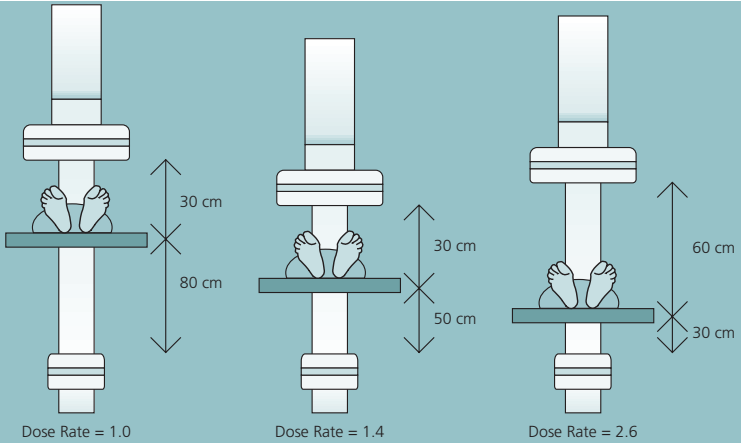

Figure supplied by L. Wagner

Table height and patient-receptor spacing are controlled by the operator. This has a major influence on patient dose. Distance between the X-ray tube and patient and spacing between the patient and image-receptor can be separately adjusted in most fixed systems. For many mobile C-arm fluoroscopes, increasing receptor spacing always decreases tube distance.

Skin dose decreases rapidly as distance from the X-ray tube increases. Collimator spacers assure a safe minimum distance. Removing them can increase maximum skin dose rates by a factor of four or more.

Skin dose also significantly decreases as the spacing between the patient and image receptor decreases.

Patient skin dose is minimized if:
Patient's skin is far from the X-ray tube.
Image receptor is close to the patient.

Collimation and Magnification

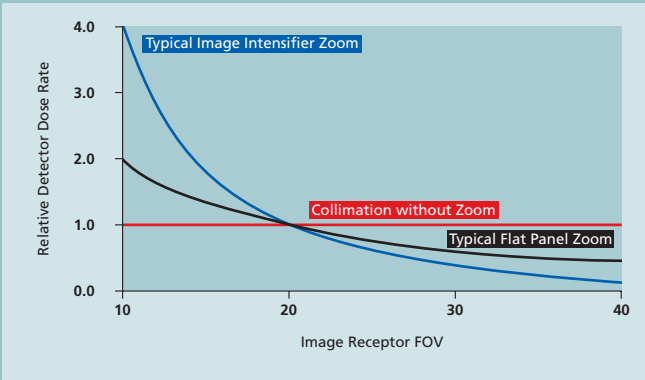

The choice of magnification (zoom) has a major effect on the image-receptor's dose requirements and on patient dose.

Smaller fields of view usually require higher dose rates than larger FOVs. Image intensifiers require an increase inversely proportional to the square of the input diameter (D). Flat-panel systems typically increase dose inversely proportional to the input field diagonal (D) or its square. The selected factor balances patient dose and image noise. KAP is unaffected by magnification in II systems and usually decreases with increasing magnification for FP systems.

Collimating within the FOV has little effect on dose for all systems. Collimation always decreases KAP.

Exposure rates usually vary by $1/D^2$ for image intensifiers and between $1/D$ and $1/D^2$ for flat panel detectors.
Collimation within the FOV always decreases KAP.

Managing Patient Radiation

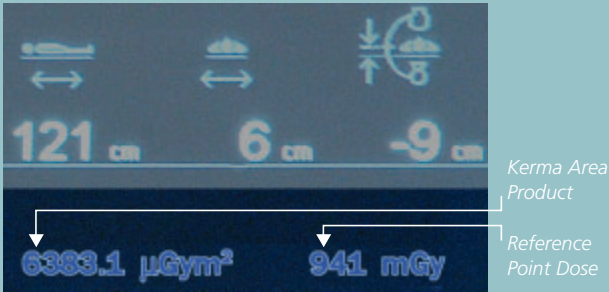

Many kinds of fluoroscopes are used for interventions. Important variables include the type and location of the controls, the location of dose displays, and the programming behind all those buttons. A brief “check-ride” on each fluoroscope minimizes inadvertent use of unwanted radiation.

Patients vary in size, shape, and location of the target organ. Factors such as previous procedures and biological variability may increase risk. All these items should be considered both while planning and performing a procedure.

KAP and/or “mGy” are displayed in the lab and at the controls. Tracking radiation use as part of the ongoing clinical benefit-risk balance should be as automatic as tracking iodine use.

- Know how your equipment works.
- What are the patient’s radiation risk factors?
- Manage radiation as well as you manage iodine.

Pre and Post Procedure

Pre Procedure Checklist

Evaluate patient's radiation risk factors

- Weight
- Previous interventions
- Previous or planned radiation therapy
- Clinical factors

Communicate radiation and other risks

- Tailor radiation consent to patient risk
- Based on risk factors, notify the patient that "significant amounts of radiation may be needed".
- Answer any patient questions

Post Procedure Checklist

Significant amounts NOT used

- Tell "notified" patients that significant amounts were not needed.

Significant amounts used

- Tell all patients that significant amounts were needed to complete the procedure.
- Discuss possible skin and hair effects
- Supply call in contact number

Follow up

Contact all significant dose patients 30 days post procedure.

Arrange appropriate consult for all patients with possible radiation injury.

Radiation is one factor in the clinical equation. Communicate with patients both before and after procedures.
Follow up all suspected radiation injuries.

Professional Considerations

Dose Limits:

There is no regulatory limit on the radiation dose that can be administered to a patient during an interventional procedure. However it is prudent to use radiation as appropriately as one uses medications or contrast media.

Significant Dose:

The significant dose trigger reminds the operator that the amount of radiation already used is high enough to take radiation explicitly into the ongoing clinical benefit-risk evaluation. The numerical value of the trigger is established by the laboratory director considering available technologies, procedures, and patient populations. Different triggers should be defined for different patient/procedure combinations.

The cumulative dose triggers used in the adult cardiac catheterization laboratory for coronary artery PTA on "new" patients are:

3,000 mGy at IRP	Monitoring person notifies operator.
5,000 mGy at IRP	Operator documents justification for the use of significant amounts of radiation. Patient is notified of significant dose usage, follow-up is arranged. 30 day telephone follow-up is scheduled.
10,000 mGy at IRP	Medical physics is requested to perform a detailed analysis.

Do not use more radiation for a procedure than you can clinically justify.
Follow up after significant dose procedures.

Patient and Family Questions

IS IT SAFE TO BE NEAR THE PATIENT?

YES! Patients are never made radioactive by any length fluoroscopic procedure.

WILL THE PROCEDURE HURT MY CHILDREN?

(Non-pregnant) If you become a parent after the procedure, there is a very small chance of a genetic effect. The risk is small compared to natural causes.

(Pregnant) Performing the procedure using fluoroscopy is the safest alternative for both you and your baby. We will do as much as possible to avoid X-raying your baby.

WILL I CATCH CANCER FROM THE PROCEDURE?

Scientific authorities predict an increase in cancer when exposed to any amount of radiation. The significance depends on the nature of the procedure as well as on your age and medical condition. In most cases the cancer risk is minimal.

WILL MY SKIN OR HAIR BE INJURED?

In medically important situations, significant radiation is needed. This can cause hair loss or skin injury. You will be told before the procedure if this is possible, and after the procedure if it happened.

Patients are never a radiation hazard to others after their fluoroscopic procedures.

Radiation is one of the smallest of the risks associated with an interventional procedure.

Web Sites with Additional Information

<http://www.cumc.columbia.edu/dept/radsafety/>

Columbia University Medical Center
Radiation Safety Department – Home Page

<http://www.fda.gov/cdrh/radinj.html>

United States Food and Drug Administration
Fluoroscopy Home Page

<http://dceg.cancer.gov/InterventionalFluor.pdf>

United States National Cancer Institute
Interventional Fluoroscopy

<http://www.acc.org/qualityandscience/clinical/competence/fluoro/index.pdf>

American College of Cardiology
Fluoroscopy Clinical Competence

<http://www.jvir.org/cgi/reprint/15/5/423.pdf>

Society of Interventional Radiology
Quality Improvement Guideline: Dose Recording

http://www.uth.tmc.edu/radiology/exhibits/koenig_wagner/index.html

Scientific Exhibit on Fluoroscopy Radiation Injuries

<http://www.bt.cdc.gov/radiation/pdf/crphysicianfactsheet.pdf>

United States Center for Communicable Diseases
Cutaneous Skin Injury Fact Sheet

http://www.icrp.org/docs/Rad_for_GP_for_web.pdf

International Commission on Radiation Protection
General Radiation Information

http://www.icrp.org/educational_area.asp

International Commission on Radiation Protection
Additional Information

www.siemens.com/wbt-dosemanagement

Siemens e-learning website with radiation training



Because we CARE.

Your main interest is the well-being
of your patients – so is ours.

Exposure is a matter of concern for
the patient during any radiological
examination. From the viewpoint of
occupational safety, exposure
reduction is of major importance.
With the Artis CARE package,
we have implemented a range of
highly innovative solutions for dose
reduction that help to lower radiation
exposure for patients and staff.

www.siemens.com/wbt-dosemanagement

SIEMENS
medical